

Ultimaker 3

# Specification sheet

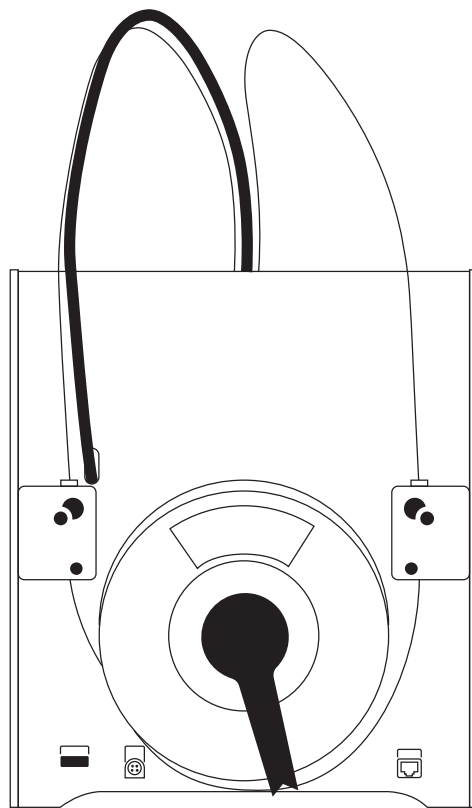
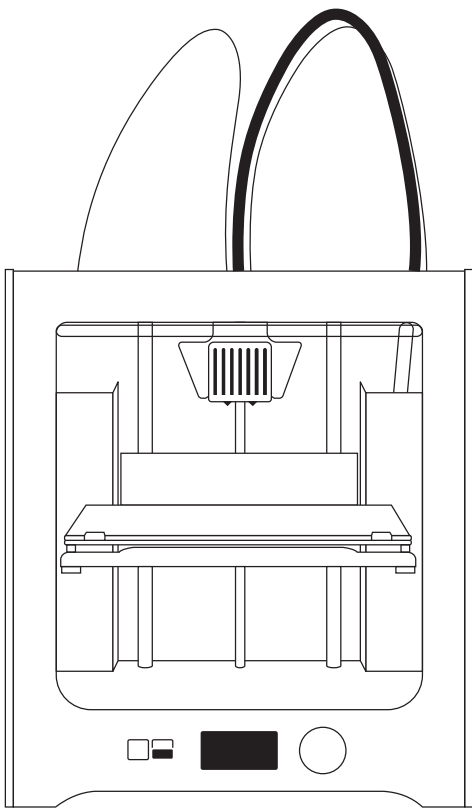

# Specifications

## Printer and printing properties

<b>Technology</b>	Fused deposition modeling (FDM)
<b>Print head</b>	Dual-extrusion print head with an auto-nozzle lifting system and swappable print cores
	Left nozzle: 215 x 215 x 200 mm
	Right nozzle: 215 x 215 x 200 mm
<b>Build volume</b>	Dual material: 197 x 215 x 200 mm
	2,85 mm
<b>Filament diameter</b>	0,25 mm nozzle: 150 - 60 micron
<b>Layer resolution</b>	0,40 mm nozzle: 200 - 20 micron
	0,80 mm nozzle: 600 - 20 micron
<b>XYZ accuracy</b>	12,5, 12,5, 2,5 micron
<b>Print head travel speed</b>	30 - 300 mm/s
<b>Build speed</b>	< 24 mm <sup>3</sup> /s
<b>Build plate</b>	Heated glass build plate
<b>Build plate temperature</b>	20 - 100 °C
<b>Build plate leveling</b>	Active leveling
<b>Supported materials</b>	Nylon, PLA, ABS, CPE, CPE+, PC, TPU 95A, PP, PVA, Breakaway
<b>Nozzle diameter</b>	0,25 mm, 0,40 mm, 0,80 mm
<b>Nozzle temperature</b>	180 - 280 °C
<b>Nozzle heat up time</b>	< 2 min
<b>Build plate heat up time</b>	< 4 min (20 - > 60 °C)
<b>Operating sound</b>	50 dBA
<b>Material recognition</b>	Material recognition with NFC scanner
<b>Connectivity</b>	Wi-Fi, LAN, USB port
<b>Monitoring</b>	Live camera

## Physical dimensions

<b>Dimensions</b>	342 x 380 x 389 mm
<b>Dimensions (with bowden tube and spool holder)</b>	342 x 505 x 588 mm
<b>Nett weight</b>	10,6 kg
<b>Shipping weight</b>	15,5 kg
<b>Shipping box dimensions</b>	400 x 395 x 590 mm

## Power requirements

<b>Input</b>	100 - 240 V
	4 A, 50 - 60 Hz
	221 W max.
<b>Output</b>	24 V DC, 9.2 A

## Ambient conditions

<b>Operating ambient temperature</b>	15 - 32 °C, 10 - 90% RH non condensing
	See material specifications for optimal conditions
<b>Nonoperating temperature</b>	0 - 32 °C

## Software

<b>Supplied software</b>	Cura, our free print preparation software
<b>Supported OS</b>	MacOS, Windows, and Linux
<b>File types</b>	STL, OBJ, X3D, and 3MF
	G and GCODE
	BMP, GIF, JPG, and PNG