



THE MOST PRECISE COMPACT SLS SYSTEM FOR ALL INDUSTRIES

www.sinterit.com



EVERYTHING YOU NEED TO BE INDEPENDENT SLS USER

Powders



Instructions/support

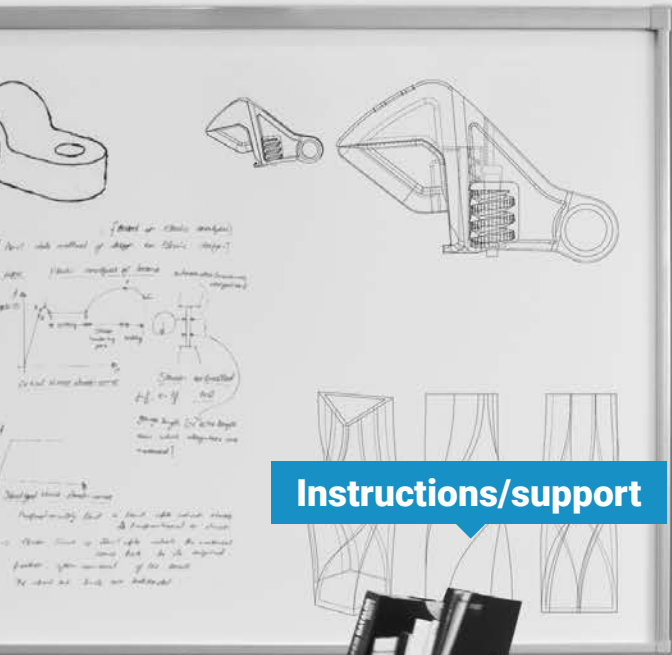

Accessories

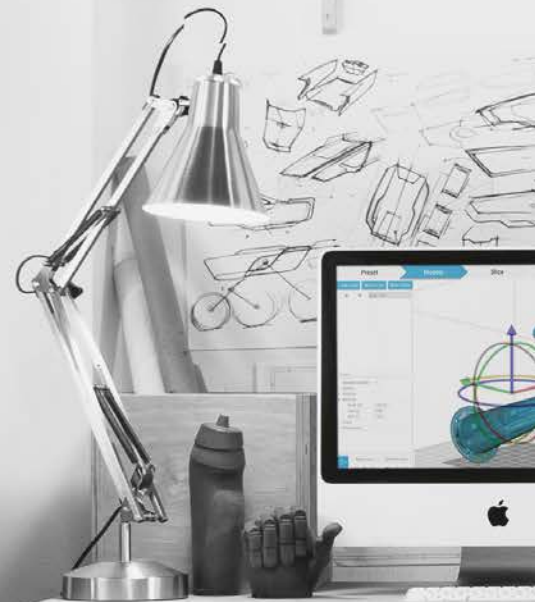

Sinterit, the manufacturer of the additive technology products, developed an **end-to-end system** for selective laser sintering.

With two professional **SLS 3D printers**, peripheral devices and the **whole range of powders**, we extended the possibilities not only for SMEs but also for academics, medical professionals, military companies and fashion designers.

We are engineers working for engineers.



Printer



Software

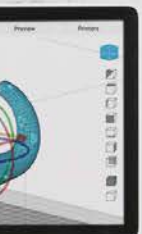

Powder Sieve



Sandblaster



WHY OUR SLS 3D PRINTERS?

Both **Sinterit Lisa** and **Lisa Pro** are the choices of professionals who look for:

- **Cost-efficiency**, a small amount of powder is needed to start printing.
- **Independence** to work on confidential projects without third parties involved.
- A **broad range of powders** from PA to TPU groups with more material to be launched.
- **Open parameters** to change the settings and test more materials.
- **Small size device**, while little space needed to set-up a printer. It fits in every office space.
- **Easy maintenance**, as there is no calibration or trained operator required.
- **Streamlined workflow** with faster cooling time, and peripherals like Sandblaster and Sieve to post-process the printouts with ease.

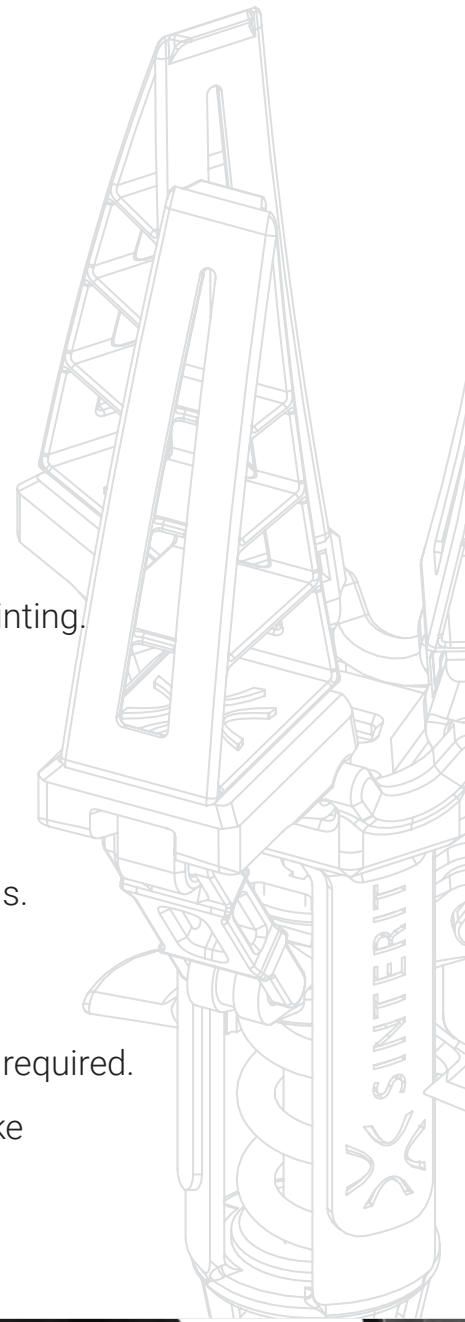

LISA CARE PLAN



You can not afford delays. It is one of the reasons you decided to buy a 3D printer. To have control. With the **Lisa Care Plan**, it is time to go even further. It guarantees the uninterrupted printing regardless of what will happen. If your printer fails or breaks down for some reason, that will not be a problem anymore.

Let's say that we have a ghost printer. The same as yours, with identical parameters, options and set of powders you own. It can be used on your behalf every time your device is in repair. With the **Lisa Care Plan**, we will print your models in our HQ, and deliver them to you, to preserve the continuity of your projects **without any delays**. It becomes one of the most interesting add-ons in our offer.

More information on www.sinterit.com

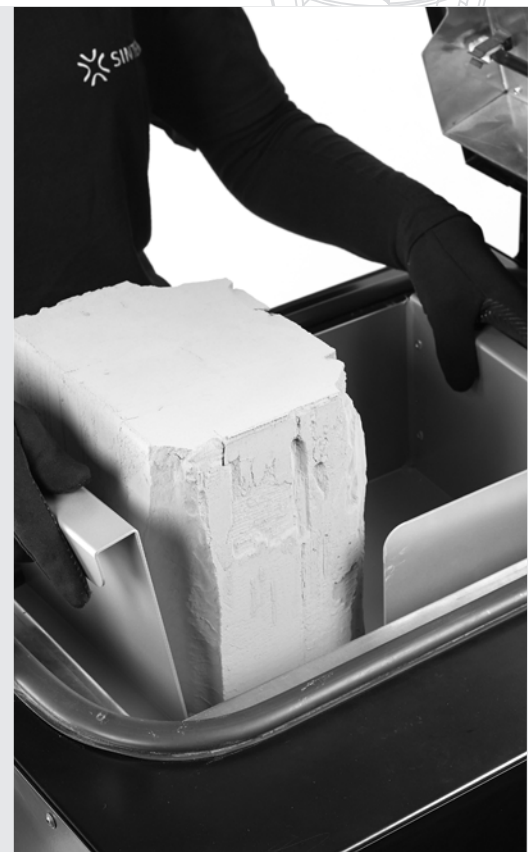

Engineers, designers, academics or medical professionals have different needs. It is why we decided to offer not only one device, but the whole additive manufacturing system, that could be configured most conveniently.

For some users, Lisa is the sufficient choice, while others would like to combine it with Lisa PRO or have several printers to assembly a small production line.

LISA PRO

Extended possibilities

We decided to introduce Lisa Pro to give engineers and designers access to even more materials and let them create prototypes or final parts that are bigger and more useful.

With the built-in nitrogen chamber and extended maximum print size Lisa Pro is the best choice if you want to test new materials and print large volume objects.

LISA

Industrial quality

For experts who want to create prototypes, new designs or produce final parts. Since the launch in 2014, it's been appreciated by engineers, medical professionals, and designers.

With Lisa, you can print from a wide variety of materials such as smooth and rigid PA12 or flexible TPUs. It's the best choice for both SLS newcomers and advanced and experienced users.





USING OUR ADDITIVE MANUFACTURING SLS TECHNOLOGY YOU CAN:

- prototype functional elements with **perfect surface quality** thanks to even 0,075 [mm] layer thickness.
- make final, low-volume engineering parts that are **durable, temperature and chemical resistant** with the high accuracy in XY axis.
- print **complicated** medical models with advanced geometry. There is no need for support structures, which could interfere with the internal structure.
- produce **movable**, mechanical parts for engineering. All **in one print**, without additional assembly.
- **spin your creativity** in areas of fashion and product design.
- get an **open parameter option** to customize printers' capabilities and meet your research needs better. With Lisa Pro, you can even **use nitrogen** to expand the list of printing powders.
- feel save with our **care plane** which protects your work-flow.

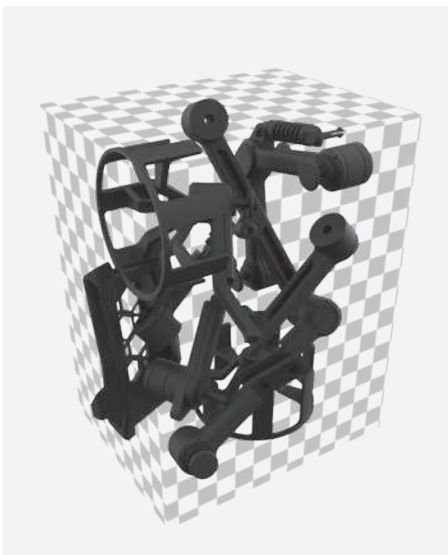

SLS SYSTEM

CHARACTERISTICS



LISA

LISA PRO

MAX PRINT VOLUME		
Diagonally [mm]	238	311
X x Y x Z [mm]		
For thermoplastic polyurethane compounds (TPU)	110 x 150 x 150	110 x 150 x 250
For polyamide/nylon compounds (PA)	90 x 130 x 130	90 x 130 x 230
PRINTER PARAMETERS		
Laser system	IR Laser Diode 5 [W]; $\lambda = 808$ [nm]	
Independent heating system	YES, heated piston, cylinder, Feed Bed, Print Bed	
Nitrogen chamber	NO	Consumption: 0,48 [m ³ /h]
Open parameters	On request	YES, Max temp.: 210 [°C] / 392 [°F]
Power supply	220-240 [V] AC, 50/60 [Hz], 7 [A] or 100-130 [V] AC, 50/60 [Hz], 15 [A]	
Average power consumption	0,9 [kW]	1,0 [kW]
Weight	41 [kg]	90 [kg]
Main features	Space and cost-effective WiFi connectivity Resistive, color touchscreen 4" Easy maintenance Easy handling	Nitrogen chamber WiFi connectivity Capacitive touch screen 7" Latest software Easy maintenance

WIDE SPECTRUM OF MATERIALS MATCHING ALL INDUSTRIES

TPU MATERIALS

FLEXA BLACK

Rubber-like, black

FLEXA GREY

Rubber-like, very elastic

FLEXA BRIGHT

Rubber-like, bright

FLEXA SOFT

Rubber-like, very soft

PA MATERIALS

PA12 SMOOTH

Durable & precise

PA11 ONYX

Strong & resistant

TPE MATERIALS

TPE

Rubber-like durable, air/water tight after sealing



SANDBLASTER FOR PRECISE CLEANING AND POLISHING

Make your prints smooth
and clean fast without effort

Dimensions

480 x 370 x 360 [mm]

Weight

15 [kg]

Working area

410 x 310 x 200 [mm]



Sandblaster requires a separate compressor/compressed air supply

POWDER SIEVE FOR YOUR CONVENIENCE

Automatically sifts used powder and makes it ready for refreshment or use

Dimensions
600 x 340 x 330 [mm]
Power consumption
24 [W]
Capacity
5 [L]
Automatic: one button only





For more info about our SLS system
contact your local distributor



If you would like to buy online, visit
our web store at www.sinterit.com/shop



Whenever you have any questions,
or you need support, feel free to contact us
at contact@sinterit.com or call [+48 570 967 854](tel:+48570967854)



Sinterit sp. z o.o.
ul. Rzemieslnicza 20G
30-363 Krakow
Poland
www.sinterit.com